

**Public Interest Energy Research (PIER) Program  
WHITE PAPER**

**Electric Distribution System Models  
for Renewable Integration  
Status and Research Gaps Analysis**

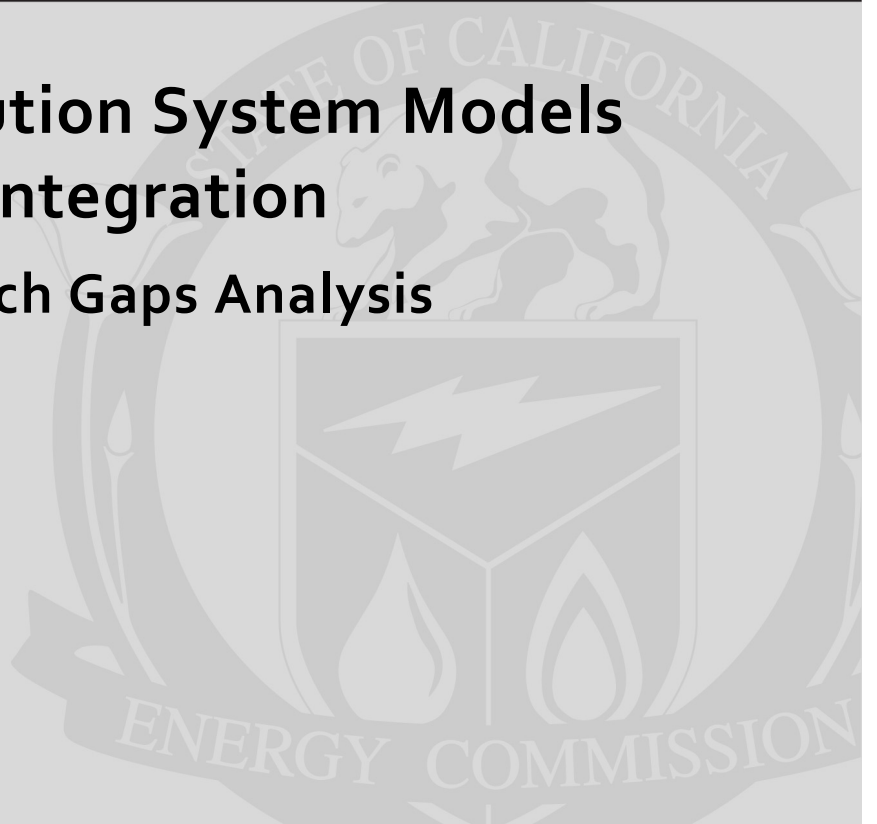

JULY 2013

CEC-500-10-055

Prepared for: California Energy Commission

Prepared by: California Institute for Energy and Environment



**Prepared by:**

**Primary Author(s):**

Larry Miller  
Lloyd Cibulka  
Merwin Brown  
Alexandra von Meier

California Institute for Energy and Environment  
University of California  
2087 Addison Street  
Berkeley, CA 94704  
916-555-1212  
www.uc-ciee.org



**Contract Number: 500-10-055**

**Prepared for:**

**California Energy Commission**

Cathy Turner  
**Contract Manager**

Jamie Patterson  
**Project Manager**

Mike Gravely  
**Office Manager**  
**Energy Systems Integration**

Laurie ten Hope  
**Deputy Director**  
**Research & Development Division**

Robert P. Oglesby  
**Executive Director**

**DISCLAIMER**

This report was prepared as the result of work sponsored by the California Energy Commission. It does not necessarily represent the views of the Energy Commission, its employees or the State of California. The Energy Commission, the State of California, its employees, contractors and subcontractors make no warrant, express or implied, and assume no legal liability for the information in this report; nor does any party represent that the uses of this information will not infringe upon privately owned rights. This report has not been approved or disapproved by the California Energy Commission nor has the California Energy Commission passed upon the accuracy or adequacy of the information in this report.

## **ACKNOWLEDGEMENTS**

The authors wish to acknowledge the technical contributions of all those we interviewed for this white paper, and the community of researchers whose conference presentations and published technical papers cited herein provided invaluable information on the state of the simulation models and on the needs of users of the technology.

Special thanks are due to the following persons for their input, guidance and support on numerous occasions: Michael Behnke, Richard Bravo, Robert Broderick, Juan Castenada, Donovan Curry, Bill Kramer, Barry Mather, Tom McDermott, Cesar Monroy, Eduardo Muljadi, and Jean Paul Watson.

The leadership and technical guidance of the Energy Commission, and in particular Jamie Patterson, Fernando Pina, Avtar Bining and Consuelo Sichon, is especially acknowledged and appreciated.

## PREFACE

The California Energy Commission Public Interest Energy Research (PIER) Program supports public interest energy research and development that will help improve the quality of life in California by bringing environmentally safe, affordable, and reliable energy services and products to the marketplace.

The PIER Program conducts public interest research, development, and demonstration (RD&D) projects to benefit California.

The PIER Program strives to conduct the most promising public interest energy research by partnering with RD&D entities, including individuals, businesses, utilities, and public or private research institutions.

PIER funding efforts are focused on the following RD&D program areas:

- Buildings End-Use Energy Efficiency
- Energy Innovations Small Grants
- Energy-Related Environmental Research
- Energy Systems Integration
- Environmentally Preferred Advanced Generation
- Industrial/ Agricultural/Water End-Use Energy Efficiency
- Renewable Energy Technologies
- Transportation

*Electric Distribution System Models for Renewable Integration: Status and Research Gaps Analysis* is the report for the Energy Commission project Distribution System Simulation Tools and Voltage Management Technologies, contract number 500-10-055, work authorization number WA004, Task 1.2: White Paper on Status and Research Gap Analysis Report on Simulation and Analysis Tools for Integration of Renewables and Electric Vehicles in Electric Distribution Systems, conducted by the California Institute for Energy and Environment. The information from this project contributes to PIER's Energy Systems Integration Program.

For more information about the PIER Program, please visit the Energy Commission's website at [www.energy.ca.gov/research/](http://www.energy.ca.gov/research/) or contact the Energy Commission at 916-654-4878.

## ABSTRACT

This white paper describes simulation models, the current state of the art of these models, and the research gaps for effective management of renewable resources and electric vehicles in distribution systems as California strives to achieve 33% renewable penetration by 2020 in accordance with the state's Renewable Portfolio Standard (RPS). This white paper is intended to provide information that will help target future solicitations for research toward applications that will help California better reach its renewable energy goals.

**Keywords:** California Energy Commission, distribution, renewable energy, RPS, Renewable Portfolio Standard, solar generation, photovoltaic generation, electric vehicles, renewable penetration.

Please use the following citation for this report:

Miller, Larry; Cibulka, Lloyd; Brown, Merwin; von Meier, Alexandra. (California Institute for Energy and Environment). 2013. *Electric Distribution System Models for Renewable Integration: Status and Research Gaps Analysis*. California Energy Commission. Publication number: CEC-XXX-2013-XXX.

# Table of Contents

<b>List of Illustrations .....</b>	<b>v</b>
<b>Introduction .....</b>	<b>1</b>
<i>Purpose and Scope of the White Paper.....</i>	<i>1</i>
<i>Modeling Basics .....</i>	<i>1</i>
<b>Overview of Models.....</b>	<b>3</b>
<i>Models for Distribution Analysis .....</i>	<i>3</i>
Static, Quasi-static, Dynamic and Transient Models .....	3
Network Models .....	4
Generator Models .....	5
Load Models .....	6
Short Circuit Models .....	7
<i>Resource and Economic Models.....</i>	<i>7</i>
PV Resource Models.....	8
Energy Storage Economic Models .....	8
<b>State of the Art .....</b>	<b>9</b>
<i>Generator Models .....</i>	<i>9</i>
Inverters .....	9
Photovoltaic Systems.....	9
Wind Systems .....	11
<i>Load Models.....</i>	<i>11</i>
Demand Response .....	12
Electric Vehicle Charging .....	12
Dynamic Load Models .....	14
<i>Energy Storage Models .....</i>	<i>14</i>
Distribution Analysis Models .....	14
Economic and Resource Models.....	15
<i>The EDGE Model.....</i>	<i>15</i>
<i>Short Circuit Models.....</i>	<i>16</i>
<i>Smart Transformers .....</i>	<i>16</i>
<b>Research Gaps .....</b>	<b>17</b>
<i>Generic Dynamic Inverter Models .....</i>	<i>17</i>
<i>Dynamic Short Circuit Inverter Models.....</i>	<i>17</i>
<i>PV System Aggregation.....</i>	<i>18</i>
<i>Demand Response Model for Load Composition .....</i>	<i>18</i>
<i>EV Charging Model.....</i>	<i>18</i>
<i>Model Conversion Between Simulator Tools.....</i>	<i>19</i>
<b>Conclusions.....</b>	<b>20</b>
<i>Different Perspectives and Priorities .....</i>	<i>20</i>
<i>Model Portability .....</i>	<i>20</i>
<i>Dynamic Modeling .....</i>	<i>21</i>
<i>Load Modeling .....</i>	<i>21</i>
<i>Generic Advanced Inverter Models .....</i>	<i>21</i>

References..... 21

## List of Illustrations

Figure 1 IEEE Prototype 31 Node Distribution Feeder Model ..... 5

Figure 2 Composite Load Model..... 6

Figure 3 DER Protection Coordination Issue..... 7

Figure 4 60 kW PV System..... 9

Figure 5 Sandia PV Performance Model Tutorial ..... 10

Figure 6 Thermal Response of House ..... 12

Figure 7 HVAC Apparent Power ..... 12

Figure 8 Generic Storage Model..... 14

Figure 9 Economic Modeling Flowchart ..... 15

Figure 10 EDGE Model Structure ..... 15

Figure 11 Prototype Smart Transformer..... 16

Figure 12 Outline of an EV Charging Model ..... 19



# Introduction

## Purpose and Scope of the White Paper

The purpose of this White Paper is to assist the California Energy Commission in developing potential research projects addressing the models used for distribution system simulation and analysis tools that incorporate impacts from high penetrations of renewables and electric vehicles. California utilities use these models to perform distribution system planning and analysis. The stakeholders on the Energy Commission's Technical Advisory Committee (TAC) recommended that a comprehensive review of the capabilities and research needs on modeling and models for distribution planning be considered a high priority.

This paper is a report on the status of the models used for distribution system simulation and analysis technologies and the gaps between what practitioners need and what technologies are available with particular focus on needs imposed by high penetration of photovoltaic (PV) power sources. This report will help define research plans and solicitations.

While models for a variety of purposes will be mentioned, this paper, particularly the State of the Art and Research Gaps sections will be limited to models needed to accurately simulate the needs of distribution feeders created by higher penetrations of distributed energy resources and electric vehicles. For several emerging technologies including storage, modeling efforts are largely aimed at examining the economics of the technology rather than on integration into the distribution system.

## Modeling Basics

Electric grids have been described as the world's largest machines. As with other large, complex systems, they are poorly suited to direct experimentation to determine behavior. As a result, computer simulation – modeling – is necessary to predict behavior. Models are the mathematical descriptions of specific electric system components formatted in a manner suitable for use by the particular simulation tool for which it is intended. The model of an entire subsystem, such as a distribution feeder, consists of a collection of component models and models of the lines connecting the various components.

A model is an approximation intended to be valid for a specific set of purposes. Thus a model of a photovoltaic (PV) system intended for use in power flow calculations may not be suitable for simulating the transient effects following a fault. It is impractical and inefficient for a model of a single component such as a PV system to accurately reflect behavior suitable for all types of simulations. Consequently, multiple models which serve different purposes are frequently needed for each component in a distribution system.

While a given electrical schematic or mathematical description may be an excellent representation for a particular purpose, the syntax of expressing the model to be used is unique to the simulation tool being used. A model intended for use in Gridlab-D must be converted to be used in CYMEDIST.

There are three broad classes of models required for simulation of a distribution system - equipment models, load models, and network models.

Equipment models are required for each component or aggregation of components in a network. Equipment which can change state under certain conditions must also incorporate a model of its control system. The increasing complexity of distribution with the potential addition of distributed generation, storage, microgrids, and demand response has created the need for entirely new equipment models. Models of conventional infrastructure elements such

as line segments (overhead and underground), transformers, capacitor banks, regulators, switches, circuit breakers, reclosers, and similar equipment are well developed and mature, so discussion will be limited to newer to the newer types of equipment associated with the Smart Grid.

Load models are created for different classes of customers – residential, commercial, and industrial. These models typically represent load over a 24 hour time period at various times of year. In past decades, loads were typically dominated by resistive components such as heating and incandescent lighting and inductive motors. More recently, electronic loads have become a significant portion of total loading and plug in electric vehicle (PEV) charging has the potential to dramatically change daily loading profiles.

Equipment and load models are then combined to create the overall network model used for a simulation. Many simulators incorporate tools which facilitate the creation of the network model from pre-existing utility databases such as the Geographic Information System (GIS) and Automatic Metering Infrastructure (AMI) data.

Models, once created, must be validated to insure that they reproduce the performance of the real element with sufficient accuracy for the intended purpose. For equipment models, this process usually requires comparing the behavior of the model to the known behavior of the element under the same conditions. As an example, if a large PV system were to be modeled as a combination of models for an array of PV cells and an inverter with performance as a function of solar irradiance and temperature, the model performance could be compared to actual performance when loaded with corresponding temperature and solar data. This presumes that measured data of the actual performance of the PV system is available. In actual fact, the lack of sufficient monitoring data at the distribution level can be a significant obstacle to accurate modeling of a distribution system.

# Overview of Models

Prior to the advent of distributed generation, distribution level simulation has been very limited and most of that has been static power flow. The increased use of solar power has given rise to the needs for models of newer technologies and simulations involving time at various scales to accurately understand the behavior of distribution systems. While this is the primary focus of this paper, there are also other types of models that are needed, especially resource models and economic models which examine annual production and economic value of various types of DER.

## Models for Distribution Analysis

### Static, Quasi-static, Dynamic and Transient Models

For many years, the use of simulation at the distribution level has been largely limited to static power flow simulations at the annual peak power point and short circuit current simulations. Distributed generation was limited and PV systems were largely ignored. Existing PV systems were simply absorbed as negative loads through the use of net metering data to create models for customer loads. Any PV production simply served to reduce the customer's load. That has begun to change as PV systems are being installed at an increasingly rapid rate, but static peak power flow simulations are still the dominant form of simulation on many California utility distribution feeders.

The first level of change in distribution modeling has been driven by the variable and intermittent nature of wind and PV power. The output of a PV system follows solar irradiance or wind data, so that, with a large DG system or a high penetration of small systems, a single power flow simulation at peak annual load is no longer sufficient to determine worst case voltage limits on a distribution feeder. Worst case might actually be a high voltage excursion occurring under light load when DG power production is at a maximum. Where a single static calculation was previously adequate, quasi static simulations over several hours at several times of the year may now be required. Both generator and load models must now include time components of data. Such models are called "quasi-static," although some providers of simulation tools call this type of simulation "dynamic" or "slow dynamic." In addition, the intermittent nature of DG has created the need for ramping studies, i.e. the use of DG output data with a time resolution of minutes or seconds to study the maximum rate of change likely to be experienced.

In spite of the incorporation of time to create quasi static models, they are much like static models as changes in system conditions are assumed to occur slowly enough that the system is in equilibrium at any given point in time. For many applications, this is a completely adequate assumption and static or quasi-static simulators inherently utilize this property. As long as variations in the system state are slow compared to several cycles or faster variations can be safely ignored, then quasi-static calculations will be accurate and are much faster, with simpler models, than transient or dynamic simulations.

Dynamic modeling is required when a system cannot be treated as in equilibrium during the time frames of interest. Usually, time frames are in the range of seconds and minutes. Dynamic modeling is common for transmission level issues, but has been uncommon at the distribution level, primarily used for issues such as harmonic analysis. Transmission systems contain multiple generators, each with associated controls, feedback loops, and differing time constants. As in any system with multiple feedback loops, interactions within the system, especially in response to disturbances, can lead to instabilities and inherently non-equilibrium behavior requiring dynamic modeling to reproduce.

The addition of new Smart Grid technologies is likely to introduce new needs for dynamic simulation. Microgrids are one example. A microgrid might contain PV systems, storage, fuel cells, backup diesel generators and so forth along with an automated control system. Dynamic simulations will be required to insure proper operation, islanding in the event of grid faults, and resynchronization when grid power is restored. As distribution level PV systems proliferate and automatic, fast acting control methods are introduced, dynamic modeling is expected to become more common in distribution planning.

Transient simulations typically operate on even shorter time scales than dynamic ones – seconds or fractional seconds. Highly specialized simulators are used for transient simulations and use non-linear analysis algorithms. PSCAD and Electro-Magnetic Transients Program (EMTP) tools are the commonly used programs. Very detailed models are required and simulations are highly computer and time intensive. Transient simulations are uncommon in distribution modeling, primarily used for examining transient overvoltage from lightning and for a detailed analysis of protection systems after a fault.

For both dynamic and transient analysis, it is possible to develop models of larger systems from a number of smaller subsystems or modules. However, the use of detailed switching models often leads to significant increase of the required computing time, which in turn sets practical limits on the size of the system that can be simulated. At the same time, switching models are discontinuous and therefore difficult to use for extracting the small-signal characteristics of various modules for the system-level analysis. This has led to “compromise” types of model called dynamic average-value models which approximate the original system by “neglecting” or “averaging” the effect of fast switching within a prototypical switching interval. Average value modeling has been often applied to variable speed wind energy systems, where the machines are typically interfaced with the grid using the power electronic converters. By effectively neglecting short term transient effects, these models allow dynamic simulations of larger systems with simpler, less computer intensive models.

## **Network Models**

The network model is the assembled model of the entire system to be simulated. It includes models for every element or aggregated group of elements. At the boundaries of the system, models are needed to represent any interfaces to parts of the grid which are not included. For a distribution system, this interface is usually a substation transformer with an assumed “infinite” stiffness. To create a model of a real network, most tools have provisions to import connectivity from other utility databases, particularly the Geographical Information System (GIS).

Mature models exist for conventional elements of a network. These include overhead or underground line segments, voltage regulators, circuit breakers, fuses, reclosers, capacitor banks, and similar components. Such models are not a subject of active research and development and are not considered further in this paper.

Distribution feeder structures vary widely between utilities and even within utilities. For simulation purposes which require “typical” networks rather than actual ones, several alternatives exist. Prototype distribution feeders have been developed by various organizations. IEEE under the auspices of the Distribution Test Feeder Working Group has released a number of different test feeders including an 8500 node to evaluate whether algorithms can scale up to large feeders. Figure 1 shows a 31 node test feeder created by IEEE which is particularly useful for studying impacts of EV penetration.

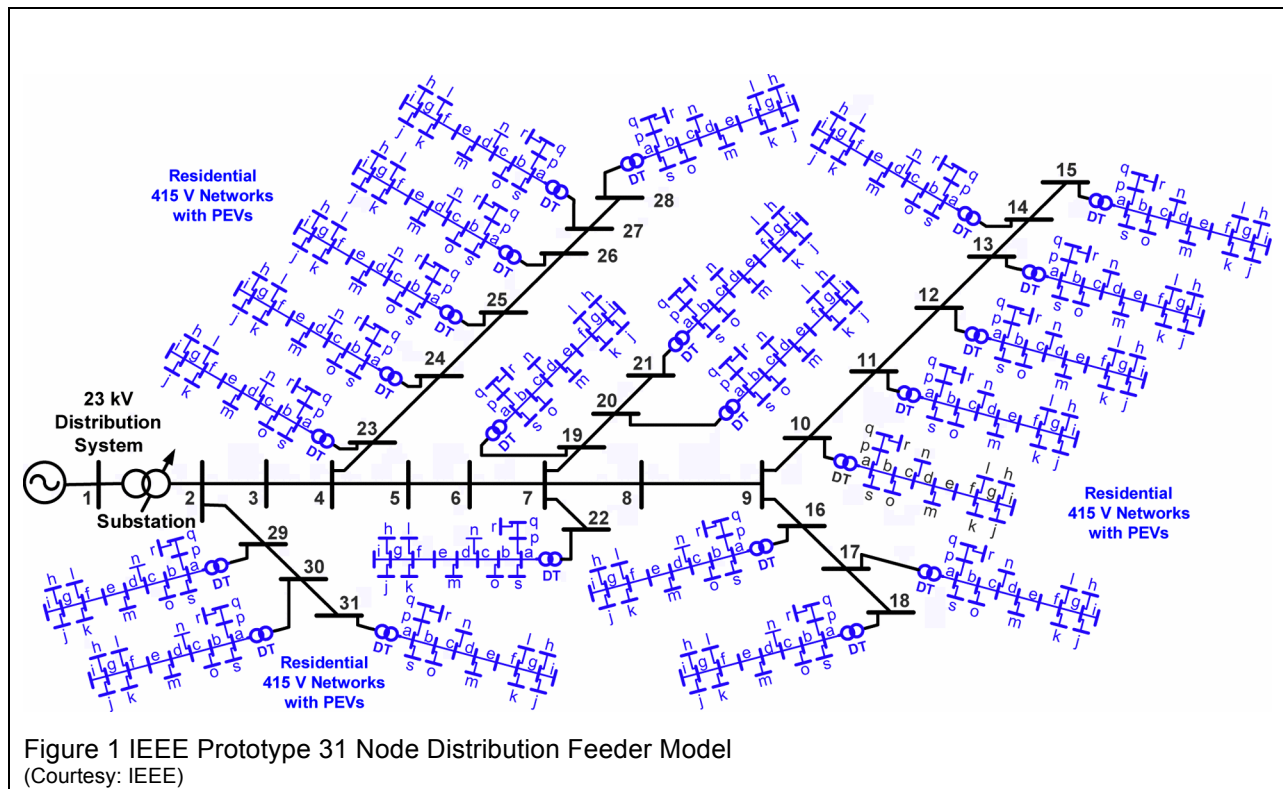

EPRI has a number of test feeders and PNNL has created a set of 24 prototype feeders categorized by climate region and intended to represent the vast majority of distribution feeder structures in use today. Each of these can then be customized to meet specific needs.

## Generator Models

Until recently, generators meant large machines with rotors, powered by fossil, hydro, or nuclear fuel, and having slow response and large inertia. Output power is set by design and control settings. With the exception of geothermal and biofuel systems, which operate much like conventional generators, renewable resource energy generators most often utilize inverters as the primary electrical interface to the grid, have fast response, little or no inertia, and have a variable and intermittent resource as a fuel supply. Output is limited by the availability of the resource and is usually not controlled to less than the maximum which is available from the system. Distribution models for such generators then are typically based on an appropriate type of an inverter model along with some type of time based data set for available output power. The appropriate type of model depends on the type of simulation.

Inverter models depend heavily on both inverter design capabilities and allowed modes of operation. The industry standard for inverters is IEEE 1547, which requires that inverters not exercise voltage control and shut off in the event of a fault. For many systems and virtually all small residential systems, inverters operate at unity power factor and output real power only. In this case, inverters can be simply modeled as current sources. However, when inverters are allowed to operate with power factors other than unity, then they are better modeled as voltage sources. There are 2 modes of operation which generate reactive power and still conform to IEEE 1547 – a fixed power factor other than unity and a variable power factor based on real output, time of day, or other factor, so long as the inverter is not acting to control voltage.

Advanced inverters can be operated to provide reactive power to support voltage, voltage ride through capability, and other benefits. These voltage control functions are currently disallowed by IEEE 1547, but modifications to the standard are under consideration and this mode of

operation is envisioned as becoming increasingly important as a means of handling high penetrations of distributed generation.

For quasi-static purposes, simulations of generators typically use “PQ” models. These models are simply tables of numerical values for real power (P) and reactive power (Q) as a function of time. These models are particularly useful for power flow ramping studies with specific relatively large sources. For dynamic and transient models, specifics of the inverter design are required to simulate the detailed behavior. Design variations from one manufacturer to another make it unlikely that a common inverter model will suffice for all inverters.

## Load Models

Load modeling at distribution has received less attention than generator and resource models. Time invariant load models have been the most common form of load models, but new distribution technologies require time varying loads. Demand response, energy storage, EV charging, and voltage optimization are all examples of technologies with characteristics that can vary on a daily or seasonal basis.

In addition to the time based variations, demand response and EV charging can change the load in response to received control signals. To support analyses of these types of loads, end-use load models that accurately represent loads under various conditions are required.

For static and quasi-static simulations, load models have no explicit time dependence but do have different dependencies on voltage. The power drawn by a constant impedance load is proportional to the square of voltage while the power consumed by a constant current load is directly proportional to voltage. A constant power load is independent of voltage. End use loads are typically aggregated into one of two model types, ZIP or Exponential.

A ZIP model is the parallel combination of the 3 major types of load: constant impedance (Z), constant current (I), and constant power (P). A load is characterized with a set of 6 variables which represent the real and reactive power of each of the 3 types, each expressed as a percentage. Thus, the 3 real variables and the 3 reactive variables each sum to 100%. An exponential model represents the consumed power as proportional to voltage raised to some power, with separate exponents for real and reactive power. For both types, 2 additional variables represent the total magnitudes of real and reactive power. In typical use, these models are created for general categories of loads, e.g. industrial, residential, or commercial. Each load in a given class then uses the same fractional values. Daily load profiles are then created at 1 hour intervals to generate a daily load profile by varying the magnitude of real and reactive power coefficients, while leaving the fractional portion of each type of load unchanged.

These simplified models, however, do not accurately reflect behavior of loads which can exist in more than one state or have control inputs. One example is the HVAC system which can account for a large fraction of total power on very hot or cold days, but very little in mild weather. Another is the demand response system whereby a utility can change the setpoint of a large number of HVAC units, affecting not only the total load, but also the effect of voltage on the load. As Smart Grid technologies increase penetration, these simplified load models become inadequate to predict distribution system performance, because they will not accurately predict load behavior as a function of voltage. More sophisticated models combine the time invariant ZIP models with physical models to create composite load models. One example of this is shown in Figure 2. These

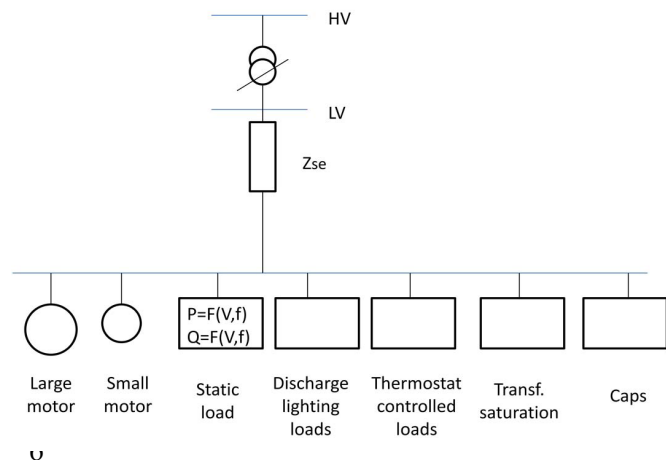

are more fully discussed in the section on State-of-the-Art.

## Short Circuit Models

Short circuit models are intended to determine the worst case currents that flow in the event of a fault and that the maximum currents will not exceed the maximum allowable currents of the various protective devices. The addition of distributed generation on a feeder creates additional sources of currents in the event of a fault. In the absence of distributed generation, the process and models for short circuit analysis is well established. Unlike synchronous generators, PV systems which form the bulk of distributed generation, have very limited capability to deliver currents in excess of ratings, typically 110% to 120% of rated maximum current. Models can simply be fixed currents at 120% of rating. While these currents tend to be small compared to the available current from the substation transformer, at high penetrations, the cumulative effect can add considerably to total current.

Maximum fault currents are not the only issue which requires short circuit modeling. Protection coordination is also an issue as protective circuits are designed as a hierarchy. Certain protective components are intended to activate before others. A simple example is shown in Figure 3. The circuit breaker is intended to trigger prior to the fuse, but given the location of DER, more current is flowing through the fuse than through the breaker and the circuit may not function as intended.

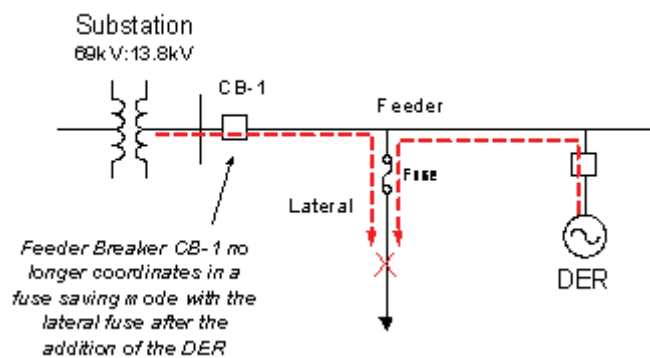

Figure 3 DER Protection Coordination Issue  
(Courtesy: Kroposky, NREL)

## Resource and Economic Models

Resource models, also called performance models, are those which are intended to simulate the performance of a generator or other type of DER system itself rather than as a component in a larger system. As such they integrate the availability of the resource itself (solar, wind, tidal) into a detailed model of each of the system elements to predict the output of the entire generator system. The typical metric for a resource model is the ratio of kilowatt hours (kWh) per year to the manufacturer's rating of peak kilowatts (kWp) the system under a set of standard conditions. Thus, the metric has units of hours and, when divided by the number of hours in a year, can be considered as the effective utilization percentage of the system.

Economic models are aimed at characterizing the economics of a system based on the annual value created by the system. Like resource models, economic models are stand-alone simulations not intended to be a part of a distribution system analysis.

Economic and resource models are often combined into a single model as there is considerable overlap between them. It often occurs that the most significant element of an economic model is the amount of resource available which must come from the resource model. Similarly, once a resource model has been created, it may be relatively simple to add the capability to determine the value.

For emerging technologies where actual penetration is low or non-existent, models for use in distribution analysis are not currently needed, although they may be required in the future should the technology become widely used.

## **PV Resource Models**

A resource model of a PV system is based on geographic location, orientation, solar irradiance, cell temperature, shading, etc. and generally contains elements not used in more general distribution analysis. Due to the specialized nature of resource models, they are primarily of interest to developers and owners of the system.

Most PV resource models utilize solar irradiance data for the location along with the system DC rating, overall DC to AC conversion efficiency, and module orientation to calculate output power per time period. More sophisticated models add the capability to vary orientation to track the sun in either 1 or 2 axes, utilize weather information (temperature and wind speed) to refine solar cell output and inverter efficiency, and can add additional impacts such as degree of soiling of the solar cells, and inverter efficiency variations due to loading. One type of model begins with the relevant solar and weather information combined with the rated DC power of the modules, and then calculates a series of independent losses to determine the AC power output. An example of this type model is from the National Renewable Energy Laboratory (NREL) called PVWatts. Available on line, this model will provide monthly results of energy and economic value produced based on historic average hourly irradiance and weather data anywhere in the United States in a 40 x 40 kilometer grid. Models such as PVWatts will often produce results accurate to about  $\pm 5\%$ , although significantly higher errors are possible. Errors such as accuracy of rated output, irradiation and weather differences of the actual location from the average, soiling, shading, and long term degradation tend to dominate the sources of error.

The primary disadvantage of models of this type is that, while they produce good estimates of overall total energy results, various errors tend to cancel, so detailed behaviors may not be accurately represented. There are several different types of solar module materials (monocrystalline, polycrystalline, thin film, polymer, etc.) which respond differently to conditions such as atmospheric haze or lowered solar irradiation.

## **Energy Storage Economic Models**

Energy storage models are inherently more complex than either generator or load models as the model must be able to replicate both source and load behavior and must also reflect the control system which dictates whether the storage unit is charging, discharging, or neither. Current penetration of energy storage at the distribution level is low enough to be considered non-existent for routine inclusion in distribution simulation.

An economic model of storage begins with a model of the particular storage technology. At the distribution level, this is most often a battery system. The battery system is characterized with power and energy levels and round trip efficiencies. Often, the most uncertain part of the battery model is the long term degradation in capacity. Inverters and a control system interface the storage technology to the grid.

The primary barrier to wider application of storage is cost. The value stream potential for storage depends on the application for which it is used. The highest value for storage is usually in providing ancillary services such as frequency regulation, while the pressure to utilize storage is primarily related to mitigating the intermittent nature of renewable resources. While a storage unit cannot simultaneously service different applications, it can provide different services at different times. It is widely accepted that an economic return for storage requires its use in multiple revenue streams and much of the focus of energy storage economic modeling today emphasizes control algorithms aimed at maximizing the economic value of a storage system.



# State of the Art

## Generator Models

### Inverters

Virtually all distribution level generators, including discharging storage, utilize inverters as the main AC generating element. These act as either a current source, if power factor is unity or a voltage source otherwise. If the dynamic or transient behavior of the inverter is not an issue, then models simply reflect the power, real or reactive that the inverter is providing. Thus, for static or quasi-static usage with a fixed power factor, models are typically PQ models that reflect the source power available at a point or series of points in time. Such models become integrated into the overall generator model such as a PV or wind system.

For dynamic and transient models, the detailed behavior of the inverter in short time frames is dependent on the specific design of the inverter and, potentially, the mode in which it is operated. Under the current restrictions of IEEE 1547, available modes of operation generally are a fixed power factor, usually unity or a few percent less, and virtually immediate shutdown in the event of a disturbance. Manufacturers have detailed models available for their particular inverters, but these are proprietary and may be difficult to obtain. Such models are based on the electronic design of the inverter and often are built up from known element models of the components.

### Photovoltaic Systems

#### *Distribution System Analysis Models*

For quasi static analyses, PV systems are represented as either negative loads or PQ models. The time varying aspect of the source data depends on the type of analysis. For ramping studies, high time resolution data of 1 minute increments or better is normally used. Figure 1 shows the variation of a 60 kW PV system as clouds pass over, typical of the type of data which might be used for such studies.

Dynamic and transient analyses require the more sophisticated inverter models, but are normally not concerned with the time varying aspects of solar irradiation. Constant power models are typically used. For short circuit modeling, EPRI studies have indicated that, while the time varying nature of fault currents will be impacted by PV systems, the alterations do not normally justify the use of EMTP type programs. For dynamic studies that do not require detailed knowledge of switching transients, somewhat simpler dynamic averaging models have been created, but are not in widespread use as dynamic modeling of distribution feeders is still in its infancy.

#### *Resource Models*

PV resource modeling is an active area of development. Sandia National Laboratories has organized the PV Performance Modeling Collaborative aimed specifically at improving the various models for PV performance. The Collaborative holds annual workshops and focuses on improving various details for use in models and widely sharing results. Figure 1 shows the many elements that can impact the performance of a PV system.

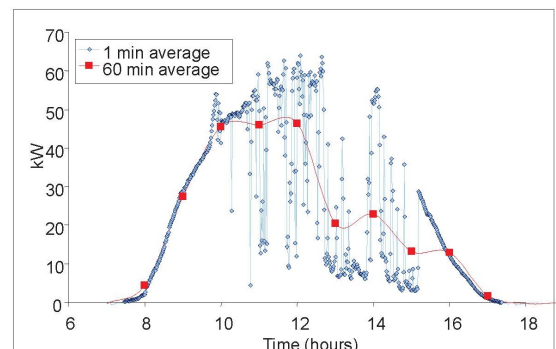

Figure 4 60 kW PV System  
(Courtesy: EPRI)

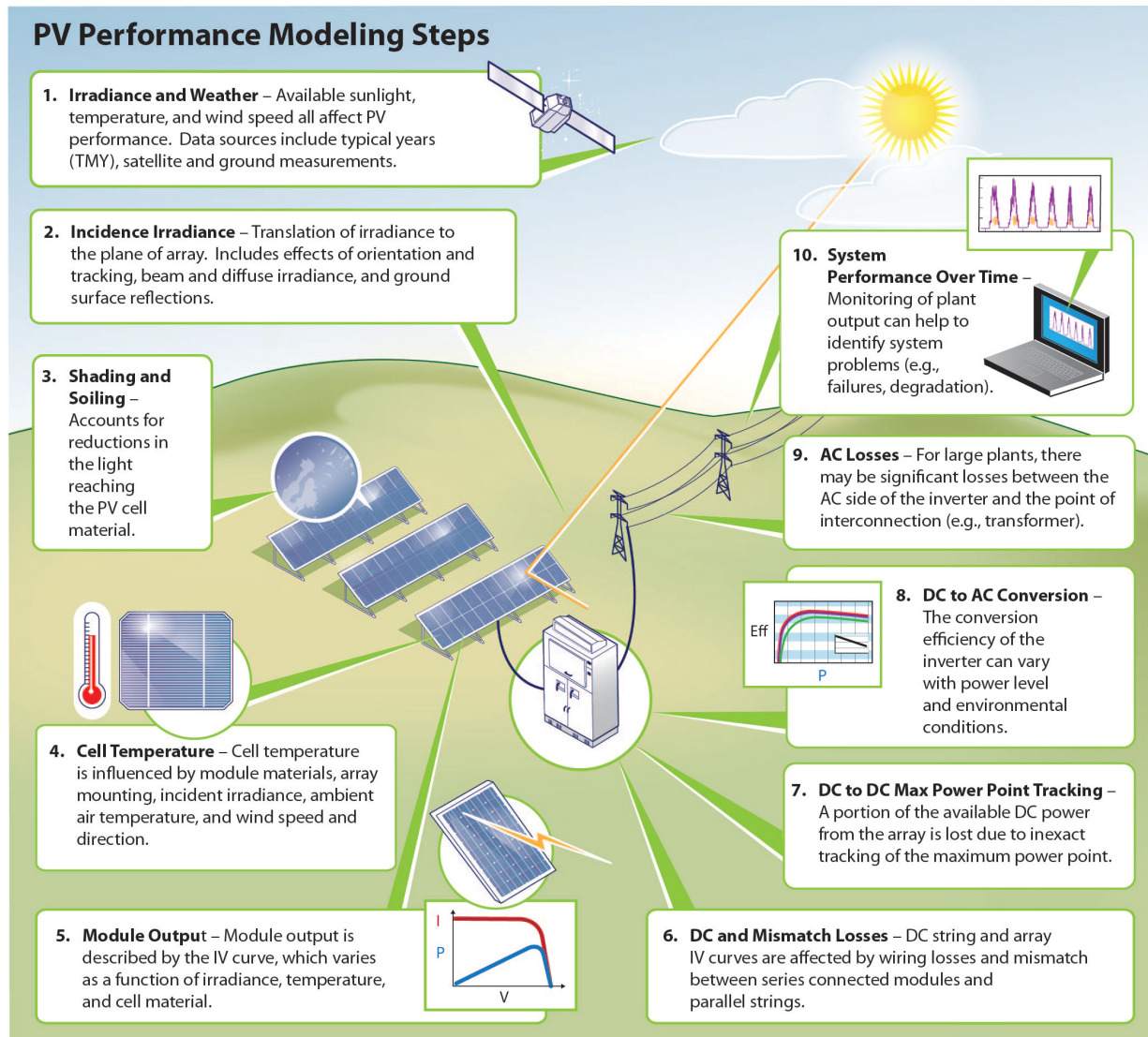

Figure 5 Sandia PV Performance Model Tutorial  
 Courtesy: Sandia National Laboratories)

There are a number of well-developed performance models available, although no single model represents is best for all purposes. The following models are representative of the state of PV performance models in mid-2013.

The System Advisor Model (SAM) is an NREL model. In addition to flat plate solar, SAM can predict performance for other types of solar (parabolic trough, power tower, etc.), wind, and geothermal sources. It has extensive capability for financial modeling of the project including computations of levelized cost of energy and net present value. Irradiance data options include TMY3 which includes hourly data for 1450 locations nationwide including 72 from California. User data can be substituted if available. For module arrays, it can use the Sandia array model with a library of over 500 commercial solar modules with predefined variables or a 5 parameter array model with user inputs for the variables. The module array can be split into up to 4 sub-arrays, each with its own orientation, shading, and soiling factors. An inverter library includes over 1100 commercial models along with some simplified generic inverter models. An NREL study comparing the SAM results with measured data produced the following accuracy estimates:

- Radiation models typically within 2%
- Module models
  - Sandia module – 5% absolute,  $\pm 3\%$  relative
  - 5 parameter model – 10% absolute,  $\pm 3\%$  relative
- Inverter model typically within 1%.

PVsyst is a commercially available PV resource model with features in many respects similar to SAM, but is focused primarily on technical performance, with more limited financial modeling. An internal database of irradiation data for 330 sites can be used or TMY3 and other sources can be imported. Hourly data can be synthesized from monthly data. It has libraries of 1750 modules and 650 inverters. It also includes component libraries for both battery and pumped storage models for off grid calculations and has a 3D drawing feature to allow computation of shading based on the layout geometry and sun path.

## Wind Systems

Large wind energy systems are becoming increasingly common at the transmission level, but are much rarer at the distribution level, and usually only as single generators. There are very few areas in California where average wind speeds at 30 or 50 meter heights, appropriate for smaller installations, are high enough for wind power to be economically viable when compared to a solar alternative. As a result, sophisticated models of wind systems are primarily based on utility scale models.

### *Distribution System Analysis Models*

For quasi-static analysis, wind models are similar to PV models, at least in principle. Wind resource data is combined with the wind turbine data detailing output power versus wind speed. Accuracy of such models is primarily limited by the availability of wind data for the precise location and altitude of the turbine hub.

Most small turbines interface with the distribution system via inverters, either single phase or 3 phases. For dynamic and transient analysis, the same types of models used for PV systems are appropriate.

### *Resource and Economic Models*

Unlike PV systems where the inverter is selected separately from the PV modules, wind turbine products include all the electrical elements. Resource models then integrate specification data from the manufacturer with wind data for the selected location. While output from a PV installation is proportional to the measured parameter of solar irradiation, power output from a wind turbine varies with the cube of wind speed. System output is therefore nonlinear with respect to the wind speed data available for a given location. Average wind speeds are indicators of expected performance, but actual output over a year depends greatly on the actual distribution of speeds more than the average.

The NREL SAM model is a good representation of the state of the art for wind performance and economic models. Economic information is entered into the model including construction costs and tariff rates. Several historical wind data sets can be incorporated, including any privately available information from the user. Some wind data is available at 30 meter height, although most is for the 100 meters more appropriate for utility scale systems.

## Load Models

Composite constructions which combine ZIP models with physical models of time varying loads represent the current state of

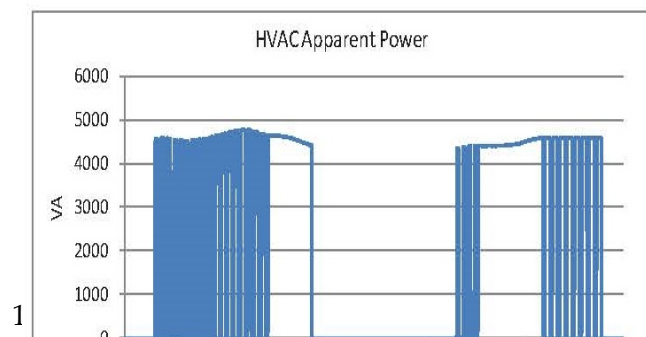

the art. Considerable work has gone into creating thermal models for buildings which allow the power consumption of an HVAC system to be predicted based on time of day, day of the week, and external temperature. Figure 2 shows the predicted thermal response for a residence as the outside temperature varies. Assumed set points were assumed to be 60° F at night and during the unoccupied portion of the day and 70° F when occupied. Figure 3 shows the power consumption of the HVAC system during the same 24 hour period

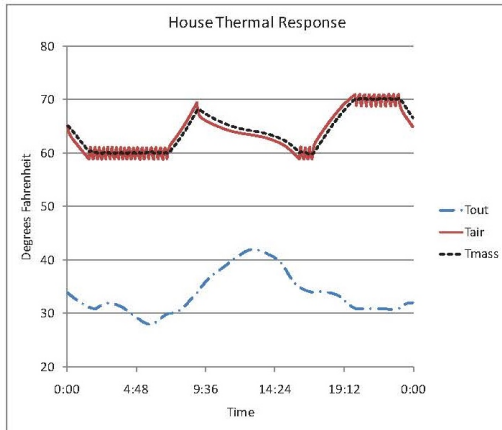

Figure 6 Thermal Response of House  
(Courtesy: K. Schneider, NREL)

Figure 7 HVAC Apparent Power  
(Courtesy: K. Schneider, NREL)

Physical and ZIP models can be combined to create composite end use models of different types of buildings and are then aggregated to create models which will more accurately predict load behavior that reflects not only voltage but other factors such as temperature. The building models are particularly useful for predicting the impact of the demand response programs whereby utilities send control signals to change thermostat set points.

## Demand Response

Demand response (DR) is a utility program aimed at encouraging customers to reduce load to achieve a help specific utility goal. To date, the primary application has been reduce peak load during times of heavy usage, usually hot summer afternoons. As PV penetration increases and demand response programs become more sophisticated, other applications will become feasible. These include balancing the variability of renewable sources and generally increasing system reliability and flexibility.

DR programs take 2 forms, direct control and customer encouragement. Under direct control, utilities (or 3<sup>rd</sup> parties) can change settings on thermostatically controlled loads or simply turn selected loads off for certain periods. In return, participating customers are compensated with lower rates. Indirectly, utilities can dynamically vary pricing to encourage customers to voluntarily reduce consumption. The actual energy reduction achieved by a DR program is estimated by determining a baseline for energy consumption without the program and then comparing the baseline to the actual consumption under the program. Uncertainty in the baseline is the primary limit to accuracy.

Current models for DR are largely aimed at determining the potential impact of DR. The Federal Energy Regulatory Commission (FERC) has published the National Demand Response Potential Model aimed at helping utilities estimate the potential energy savings from a DR program. The spreadsheet based model takes into account information on customers, load mix, existing demand response, advanced metering infrastructure deployment, air-conditioning saturation, and other relevant factors. For use in planning simulations, DR is rarely considered and then only as an estimated correction to existing load models.

## Electric Vehicle Charging

The charging of EVs is a new form of load that can potentially have a significant impact on daily load profiles. To date, however, the current penetration is not significant and changes to the type of load model have not been needed. There is however, a considerable body of research being published on longer term issues. From the standpoint of EV charging load models, the state-of-the-art is resident in the research community. While much modeling has been done,



“models” tend to be more focused on achieving a result with less concern about compatibility with specific distribution simulators.

Depending on circumstances, EV charging is potentially a significant problem - or a minimal one – or a benefit. There is general agreement that the time of charging is the critical factor. To predict loading, utilities must not only know how many EVs there are and their state of charge, but when they start charging. Modeling consists of 2 major components – those concerned with the characteristics of individual chargers and the aggregation of those chargers into the collective EV load.

An aggregate EV model must consider consumer behavior. Utility interest is strongly in the direction of influencing consumer behaviors in grid-friendly ways. Research is primarily with stochastic models with several variable factors. In addition to numbers of EVs and start time, battery size, charge rate and state of charge are also needed. In a fashion similar to the characterization of loads as industrial, commercial, or residential, EV models are likely to divide into residential and one or more classes of non-residential. Models that incorporate methods of influencing or controlling consumer behavior include may incorporate pricing strategies or utility load-response types of programs.

### Dynamic Load Models

Dynamic load models are required when quasi static analysis cannot adequately account predict results for time frame frames of interest. The Western Electricity Coordinating Council (WECC) Load Modeling Task Force has developed composite models that represent the dynamic behavior of end-use loads, with special attention to single phase residential air conditioners. These models were then aggregated into equivalent large load models for use in transmission studies. Unfortunately, the distribution system loads typically have different characteristics so more detailed load models are often required when dynamic modeling is needed. The approach, however, of a composite of time invariant and physical multi-state models is one which also applies to dynamic load models.

Technologies such as electric vehicle charging and demand response will force appliances and devices to transition between different operational states, each with unique behaviors. For example, the energy consumption of clothes dryers can change when a demand response signal indicates a high price, possibly cycling the heating coils while the motor continues to run. To properly represent the behavior of end-use loads, time-variant multi-state end-use load models need to account for operations in multiple states, including the impacts of state transitions.

### Energy Storage Models

#### Distribution Analysis Models

Compared to generator and load models, energy storage models have been the subject of a relatively small amount of research and development. Penetration of storage at the distribution level has been so low as to not require careful modeling in routine utility distribution planning studies.

Quasi static generic models such as shown in Figure 8 are used to simulate the use of storage for various purposes. The actual technology of the storage is only relevant to the extent that of specifying the round trip efficiency and idling losses. The control algorithm used to determine when to charge or discharge will vary depending on the applications for which the storage is to

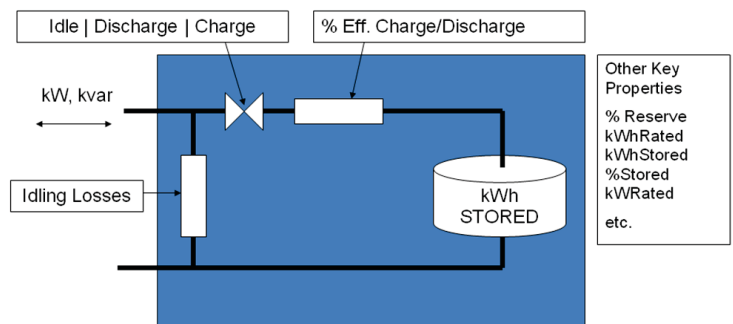

1 Figure 8 Generic Storage Model (Courtesy: EPRI)

be used. For peak load shifting, the charge discharge cycle might be a daily routine, while mitigation of intermittency of a PV system could incorporate the control into a feedback loop designed to minimize ramps during the passage of clouds.

### Economic and Resource Models

At the distribution level, batteries are the primary method of storage. The long term behavior of batteries is a difficult subject and so models which predict the long term behavior of battery storage are rare. While product manufacturers frequently have more detailed models available for their products, these tend to be proprietary and applicability is restricted to those products and may not be applicable for a general class of batteries. The models that do exist are largely those aimed at transmission level installations.

Storage is generally considered to be expensive and non-economic in many applications. As a result, there is interest in utilizing a given storage system in multiple applications to maximize its value. Economic models of storage look at the annual value and the state of the art for these models focuses on control algorithms which prioritize between multiple applications to maximize value. A typical flowchart for an economic model is shown in Figure 9. These models are most often created by researchers and appear to have minimal impact on utility planning simulations. EPRI has created the Energy Storage Valuation Tool (ESVT) which is available to funding members.

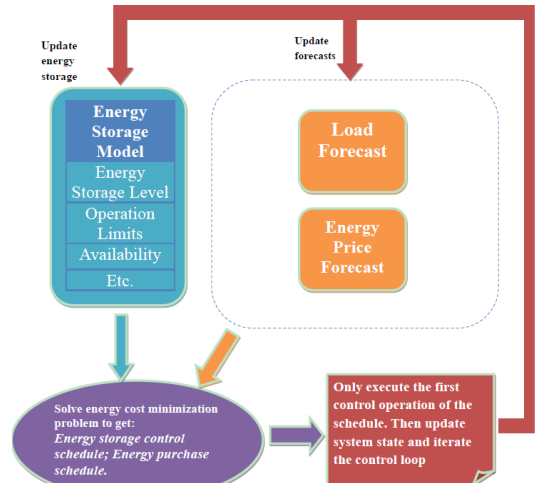

Figure 9 Economic Modeling Flowchart (Courtesy: Xu, IEEE)

### The EDGE Model

The Rocky Mountain Institute (RMI) has developed the Electricity Distribution Grid Evaluator (EDGE) model, a MATLAB-based simulation tool designed to “comprehensively assess the DER value proposition in different regulatory and utility business model environments based on a detailed assessment of the technical and operational implications.” This economic analysis model is unique in that it assesses costs and values created by all resources, including DERs, and does so from the perspective of not only utilities, but also 3<sup>rd</sup> party providers, end users, and society. Integral to the model is an analysis of distribution technical performance including voltage extremes and support requirements, network losses, and equipment usage/impacts.

Figure 10 is a schematic representation of the model. The blue areas are specific modules in the model. The model incorporates both temporal and location considerations. The Operational module contains 2

submodules, one for transmission and one for distribution. The distribution submodule utilizes OpenDSS to simulate the network under consideration and is capable of incorporating virtually all forms of DER including distributed generation, end use efficiency, demand response, storage, and electric vehicles.

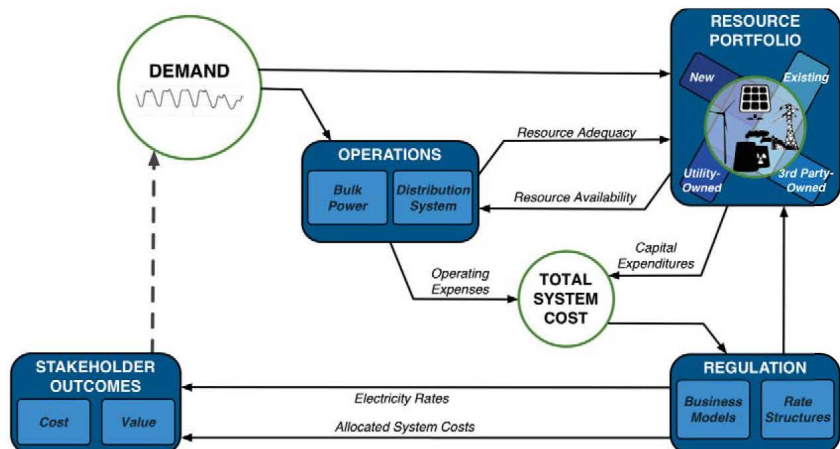

According to RMI, the EDGE model can be used to evaluate the effects of different business models and rate structures. The model considers different ownership structures including mixed ownership and control of various resources by non-utility stakeholders and analyzes the various impacts on each class of stakeholder.

## Short Circuit Models

Protective circuits are designed to prevent damage to system components in the event of a phase to ground or phase to phase short circuit. These circuits typically operate in less than 10 cycles or a timeframe of up to 170 milliseconds. During this period, devices must operate to interrupt a current which can be thousands of Amperes. Both the electrical behavior of generation devices and their control devices during this transient timeframe are extremely complex.

As this vital function has existed for decades, short circuit models of conventional thermal generators are mature. However new types of generators require new models. Renewable generators at distribution are overwhelmingly inverter based, so the short circuit models for these are transient models of inverters. Short circuit currents in inverters are limited to less than about 120% of maximum current ratings, but the duration depends on the specific design and varies with manufacturer. Advanced inverters incorporating some form of voltage ride through may not shut off prior to operation of protective devices.

On a distribution feeder, concerns over short circuit currents are primarily relevant to large 3 phase PV installations. Smaller systems including residential systems are not only current limited, but will shut down typically within a few milliseconds, a time short compared to the reaction time of protective circuits and, as such, are not normally of concern.

Currently, the state of the art in commercial distribution simulators is to utilize Thevenin equivalent current source models. These models may be inadequate in the case of unbalanced faults but there are no current standards for proper modeling and how a given manufacturer implements control systems can impact what is a valid model.

## Smart Transformers

Ever since the MIT Technology Review listed “smart transformers” as one of the 10 technology breakthroughs in 2011, the concept of replacing bulky, oil filled transformers with high power electronics and much smaller high frequency transformers, combined with digital intelligence to monitor and adjust performance has received much attention. Unfortunately, the commercial reality of such a device for use in distribution systems is still in the concept stage. Major players such as ABB have introduced “Smart Transformers” but the reality is a conventional transformer surrounded by smart sensors and an intelligent monitoring system to improve reliability and reduce maintenance costs.

Researchers at North Carolina State University have developed a working prototype and some market reports predict a bright future for smart transformers, shown in Figure 11, but a literature search has not uncovered any examples of commercially available devices or of utility field tests or demonstrations of such devices, whether commercial or not. Until feature sets have been defined and actual devices are available, development of appropriate models for utility planning purposes is unlikely.

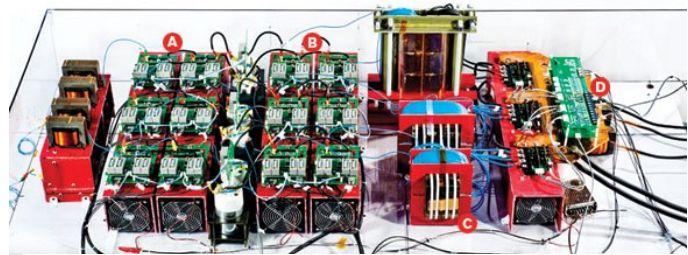

Figure 11 Prototype Smart Transformer  
(Courtesy: MIT Technology Review)

# Research Gaps

## Generic Dynamic Inverter Models

Inverters from different manufacturers react differently under circumstances of interest in dynamic simulations. While manufacturers have accurate dynamic models available, these tend to be proprietary and not readily available. Generic dynamic models that can effectively represent the vast majority of commercially available inverters do not exist. Research has suggested that commercial inverters can be grouped into a relatively small number of classes, much as wind turbines have been categorized into 4 types by the WECC Wind Modeling Task Force. Research is needed to define the types and generic dynamic models need to be created and validated for each type.

Advanced or “smart” inverters have 4 quadrant phase capability, i.e. within their output limits, they can supply current with any desired phase relative to the voltage and thus provide leading or lagging VARs in addition to real power. They are also capable of continuing to supply current in the event of a disturbance. Currently, however, the ability of inverters to perform these functions is severely constrained by the standard for grid connected inverters, IEEE 1547. Under the current standard, inverters cannot act to control voltage and they must shut down immediately after a disturbance. As a result, there has been little demand for models incorporating advanced functionality. A step in this direction will be the latest modifications of IEEE 1547 which are currently being considered for adoption and would allow use of more advanced functionality.

The capabilities of smart inverters potentially offer a wide range of useful functions including but not limited to voltage support, voltage ride through, and anti-islanding detection. Such functionality can offer significant benefits in the cost effective management of distribution systems with high levels of DER penetration, but there is no standard for what these functions are. EPRI has formed a collaborative with Sandia National Laboratories and the Solar Electric Power Association to develop a list of proposed advanced inverter functions. That list currently includes 23 separate functions including functions to facilitate storage.

As there are no standardized functions that all manufacturers will provide, different manufacturers are implementing different sets of capabilities. Until such time as alternative operating modes are standardized, advanced generic inverter models which incorporate selectable control functions would allow the model parameters to be customized to reflect the functions that actually are implemented by the manufacturer.

## Dynamic Short Circuit Inverter Models

For commercial scale PV, inverters generally share a common set of characteristics. They are 3 phase with a voltage source topology, are pulse width modulated, and are AC current regulated. While smaller inverters may not share all these characteristics, it is the commercial level of inverters that are of primary concern for short circuit analysis.

As a rule of thumb, maximum inverter currents under fault conditions are no more than 120% of rated current, but may be less. However, the reactive elements in the circuitry can cause short term transients to considerably exceed these limits. If potential fault currents are close to equipment limits, transient modeling will be needed to more accurately determine fault currents. Such models depend on the design specifics and can vary significantly from manufacturer to manufacturer. While detailed proprietary models exist, there is a lack of appropriate generic models. Such models need to consider not only the design details, but also the advanced functionality that may be used in the future. In particular, such models should



allow investigation of the impact of voltage ride through functions and anti-islanding schemes on the time needed for fault detection.

## PV System Aggregation

As penetration of PV systems increases, separate modeling of every system becomes impractical and methods of creating equivalent models for an aggregation of systems are needed. In any particular distribution feeder, there are likely few large commercial scale systems, which are likely to be individually modeled. However, large numbers of small systems can have a significant impact, but would be difficult or impractical to model individually. A system of aggregating a number of PV systems is needed. In particular, such aggregation needs to account for the geographical diversity of systems. The level of aggregation required depends on the application.

At high penetration levels of PV, the effect of passing clouds can create large, fast power ramps in the system, necessitating rapid changes to the voltage control system. For a localized system, cloud passage can create steep ramps on a time scale of seconds. As systems become more geographically diverse, the cloud passage impacts different installations at different times, causing total variations to have longer time scales and hence lower ramp rates.

Geographical diversity affects not only ramp rates. Voltage extremes depend on the locations of generators. It would be expected that aggregation would involve some form of clustering algorithm that would replace a large number of small systems with a much smaller number of “equivalent” generators at appropriate locations.

## Demand Response Model for Load Composition

DR is already being used by California utilities to reduce peak loading. In the future, additional applications include reducing wholesale prices and their volatility, improving system reliability and flexibility, and helping to balance power variations from intermittent renewable resources. To allow for these more advanced applications, an explicit model of demand response integrated into an overall composite load model is needed.

DR can take multiple forms. A utility can directly control a customer’s appliance. Alternatively a utility can institute a dynamic rate structure that incentivizes customers to reduce usage at particular times. A third party can aggregate a number of end users and sell negative load to the utility. A DR model should be able to reflect the characteristics of any of the different types including the expected response time to a DR signal, particularly any timing issues associated with turning devices back on that have been turned off.

## EV Charging Model

Each EV battery can consume as much or more energy than an entire household. As EV penetration increases, the need becomes stronger for EV charging to be explicitly modeled as part of the overall load. To be useful, a model must consider the number of batteries, the size and state of charge of the batteries and the start times and rate of charge. These must be aggregated into a collective battery charging load profile associated with each load profile in the simulation. Figure 6 shows one suggestion for an outline of the structure of an EV load profile.

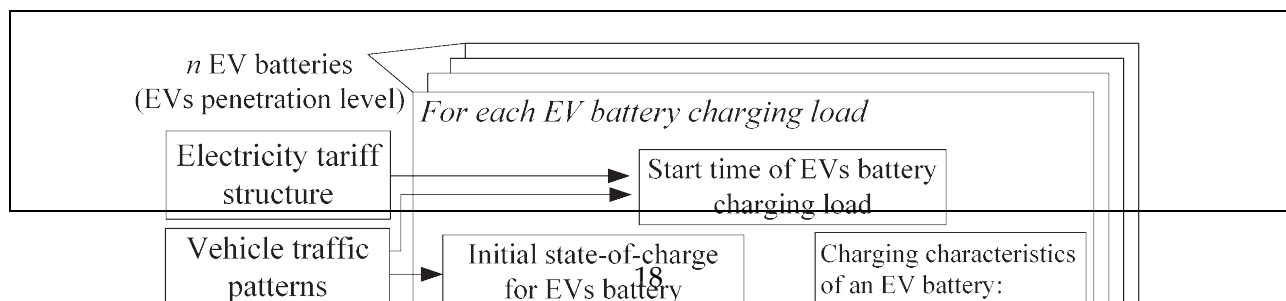

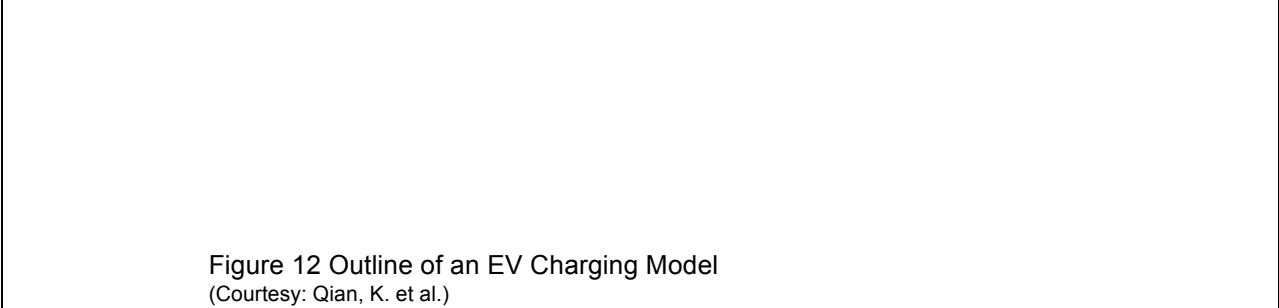

Figure 12 Outline of an EV Charging Model  
(Courtesy: Qian, K. et al.)

## Model Conversion Between Simulator Tools

Simulation tools such as GridLAB-D and OpenDSS have been developed for use in quasi-static distribution simulations and are particularly useful in studies of distribution systems with high penetrations of DER. As a result, researchers have developed a large variety of models considered useful for that purpose. In contrast, commercially available distribution tools such as CYMDIST and SynerGEE have historically focused on static simulation and are gradually adding more capability in quasi-static analysis. Within these programs, however, models of various types of DER tend to be oversimplified or not available at all. Converting models from one system to another can be quite labor intensive.

Utility engineers are familiar with the program that the utility has long utilized for planning purposes and generally prefer to work with the familiar program rather than develop a similar expertise on another program. A tool which effectively converts a model from one simulator's format to that of another is needed to better utilize available resources and to take advantage of model development work that has been done.

## Conclusions

This white paper is the result of an extensive literature search and a series of conversations with distribution modeling experts from California utilities, national laboratories, and universities. An overview of models and modeling has been presented along with an assessment of the state of the art for various types of models and the research gaps which exist between current capabilities and perceived future needs as PV and EV penetration grow to significant levels. The following is a set of conclusions reached by the authors as a result of research for this white paper.

### Different Perspectives and Priorities

The conversations with experts were particularly informative, not only because of specific information about models, but about a more general sense of significant differences between researchers from universities and national laboratories and the utility engineers who actually performed distribution level simulations. These differences are significant enough to impact the utility of future research if not considered:

- **Time horizon**  
Utility engineers are strongly focused on the short term, typically 1 year. While long term planning is certainly done, most of the simulation is to examine fairly immediate considerations. Researchers at the national laboratories, on the other hand, tend to be concerned with future trends and needs and have been the best sources on what future capabilities will be required.
- **State of the Art**  
The most advanced work and most sophisticated models are invariably done by the researchers, while state of the art for utilities tends to be considerably lower. As an example, recent research papers tend to focus on dynamic models and simulation. Utility engineers, on the other hand, are still doing static simulations wherever possible and have only recently started to do extensive time series simulations.
- **Tools**  
Researchers are utilizing GridLAB-D and OpenDSS extensively for quasi-static modeling and many of the most advanced models are developed for use in these tools. Utility engineers, however, tend to favor the commercial tools such as CYMDIST and SynerGEE. These are the tools which their utilities have purchased and which have ongoing relationships with the vendors for support. They prefer models which the vendors have developed and incorporated into the program so that the modeler can simply select (rather than create) the model. Network models are likely to already exist in this format. The utility engineers typically have heavy work schedules and are already under considerable time pressure due to the rate of change that is occurring everywhere in their industry. The time required to learn and become proficient with a new program is a significant impediment. The compatibility of commercial planning tools with operational software is another reason why the commercial products are preferred. Perceived unmet future needs are frequently dealt with by pressuring the vendor to make improvements to their tools to accommodate the new needs. Vendors are, in fact, responding to these pressures and new models and capabilities are being added to commercial distribution simulation products.

### Model Portability

Today, many of the most advanced models for quasi static use have been developed for use in GridLAB-D or OpenDSS. Ideally, any developed model could be used in any program suitable

for that type of model. Such standardization does not exist and is unlikely to exist in the next few years. More practical would be a software tool which would easily convert a model in one format to another, in particular, one (or more) that would convert from these research tools into formats compatible with the major commercial programs, especially CYMIST and SynerGEE, two of the most widely used simulators.

## Dynamic Modeling

Dynamic modeling is currently little used by utilities in distribution although it is required for harmonic studies and transients. As PV penetration increases, various other distributed resources will be increasingly utilized to mitigate the impacts. These may include energy storage, active Volt/VAR control, advanced inverter capabilities, and other methods of more automated control. As time frames of interest shift from hours to seconds or shorter, dynamic modeling will be increasingly required to provide accurate results. Dynamic models of all types are far less developed than static or quasi-static models and will be required within a few years.

## Load Modeling

The nature of loads is changing and requires improved load models. There is a general long term trend of increased use of electronic loads as more and more devices utilize inverter power supplies. Larger changes, however, are on the horizon. One, in the form of EV charging, can ultimately represent total loads equivalent to adding a large fraction of new customers and where the load profile vs. time can be strongly influenced by utility policies. Another is DR, which is expected to increase its role as penetration increases and new applications beyond peak reduction are added.

## Generic Advanced Inverter Models

While IEEE 1547 currently limits the use of many proposed functions of advanced inverters, it is likely that these restrictions will be modified in the near future. There are many possible advanced functions that would make inverters more useful in Volt/VAR control and other applications. EPRI has created an extensive list of possible functions. However, there is no standardization of feature sets and different manufacturers offer products with different feature sets and even different implementation of features which serve the same purpose. Standardization of feature sets would be ideal, but unlikely in the near future.

From a dynamic standpoint, different products can behave differently. Manufacturers often have proprietary models, but generic models that represent broad classes that encompass the large majority of available inverter dynamic behaviors and also incorporate advanced features such as voltage ride through are needed.

## References

Behnke, M., *Generic Solar Model Status*, Western Electricity Coordinating Council Renewable Energy Modeling Task Force Meeting, 2012

Behnke, M., *Short Circuit Contribution from PV Power Plants*, EERE Distribution Modeling Workshop, 2012

Cao, Y., et al., *An Optimized EV Charging Model Considering TOU Price and SOC Curve*, IEEE Transactions on Smart Grid, VOL. 3, NO. 1, 2012

Chiniforoosh, S. et al., *Definitions and Applications of Dynamic Average Models for Analysis of Power Systems*, Power Delivery, IEEE Transactions on (Volume:25 , Issue: 4 ), 2010

- EPRI, *Common functions for Smart Inverters, Version 2*, <http://www.epri.com/abstracts/Pages/ProductAbstract.aspx?ProductId=00000000001026809>, 2012
- EPRI, *Section 9 Distributed Generation Modeling Guidelines*, [http://disgen.epri.com/downloads/09-DGModelingGuidelines\\_Revised.PDF](http://disgen.epri.com/downloads/09-DGModelingGuidelines_Revised.PDF), 2009
- Ferguson, T., *SAM Wind Analysis*, [https://sam.nrel.gov/webfm\\_send/99](https://sam.nrel.gov/webfm_send/99), 2011
- Gonzalez, S., *Next Generation of PV Inverter Technologies: Photovoltaic and Distributed Systems Integration*, <http://energy.sandia.gov/wp/wp-content/gallery/uploads/6-Next-Gen-Inverter-Technologies.pdf>, 2013
- Heshmati, A., *Survey of Models on Demand, Customer Base-Line and Demand Response and Their Relationships in the Power Market*, Institute for the Study of Labor (IZA), 2012
- Hoffman, M.G., et. al, *Analysis Tools for Sizing and Placement of Energy Storage in Grid Applications*, [https://solarhighpen.energy.gov/resource/analysis\\_tools\\_sizing\\_and\\_placement\\_energy\\_storage\\_grid\\_applications\\_literature\\_review](https://solarhighpen.energy.gov/resource/analysis_tools_sizing_and_placement_energy_storage_grid_applications_literature_review), 2010
- Kadurek, P.; Cobben, J.; and Kling, W., *Smart Transformer for Mitigation of Voltage Fluctuations in MV networks*, 10th International Conference on Environment and Electrical Engineering (EEEIC), 2011
- Kropowski, B., *Distribution System Models Power System Studies and Modeling PV Inverters*, NREL Utility/Lab Workshop on PV Technology and Systems, 2010
- Mathieu, J., *Modeling, Analysis, and Control of Demand Response Resources*, EETD Communications Seminar, <http://vimeo.com/41299446>, 2012
- Muljadi, E.; Singh, M.; and Gevorgian, V., *Dynamic Model Validation of PV Inverters Under Short-Circuit Conditions*, <http://www.nrel.gov/docs/fy13osti/57341.pdf>, 2013
- Roy, N. K.; Hossain, M. J.; and Pota, H. R., *Effects of Load Modeling in Power Distribution System with Distributed Wind Generation*, 21st Australasian Universities Power Engineering Conference (AUPEC), 2011
- Nimpitiwan, N., *Inverter-Based Photovoltaic Distributed Generations: Modeling and Dynamic Simulations*, IEEE Region 10 Conference TENCON 2010, 2010
- Qian, K.; Zhou, Z.; Allan, M.; and Yuan, Y., *Modeling of Load Demand Due to EV Battery Charging in Distribution Systems*, IEEE Transactions on Power Systems, Vol. 26, NO. 2, 2011
- Ransome, S. and Sutterlueti, J., *The Sensitivity and Limitations of Present and Alternative PV Models*, 2013 PV Performance Modeling Workshop, 2013
- Ransome, S.; Sutterlueti, J.; and Sellner, S., *PV Technology Differences and Discrepancies in Modelling between Simulation Programs and Measurements*, IEEE Photovoltaic Specialists Conference (PVSC), 2012
- Sandia National Laboratories, *Sandia National Laboratories: Tutorial on PV System Modeling*, [http://energy.sandia.gov/?page\\_id=9007](http://energy.sandia.gov/?page_id=9007), 2012
- Schneider, K.; and Fuller, J., *Detailed End Use Load Modeling for Distribution System Analysis*, IEEE Power and Energy Society General Meeting, 2010
- Schneider, K.; Fuller, J.; and Chassin, D., *Multi-State Load Models for Distribution System Analysis*, IEEE Transactions on Power Systems, Vol. 26, NO. 4, 2011

She, X. et al., *Review of Solid State Transformer in the Distribution System: From Components to Field Application*, IEEE Energy Conversion Congress and Exposition (ECCE), 2012.

Shirek, G.K.; Lassiter, B.A., *Solar Plant Modeling Impacts on Distribution Systems: PV Case Study*, Rural Electric Power Conference (REPC), 2012 IEEE, 2012

Tang, Y.; Mao, X.; and Ayyanar, R., *Distribution System Modeling using CYMDIST for Study of High Penetration of Distributed Solar Photovoltaics*, North American Power Symposium (NAPS), 2012

Taylor, J., *Distribution Modeling for Integration of PV, PEV, and Storage*, 2011 IEEE PES annual meeting presentation, 2011

Tian, H., et al., *A Cell-to-Module-to-Array Detailed Model for Photovoltaic Panels*, Solar Energy Volume 86, Issue 9, 2012

Zhao, T., et al., *An Average Model of Solid State Transformer for Dynamic System Simulation*, Power & Energy Society General Meeting, 2009.